

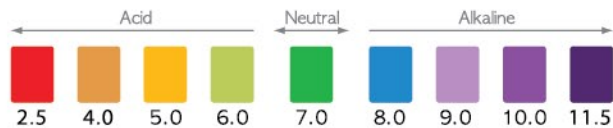

[www.tyentusa.com](http://www.tyentusa.com)

- The user is responsible for improper use of the products such as use in any manner for which the product was not originally intended and any damage that may occur from such improper use.
- This product is subject to changes that enhance its performance without prior notification.

### pH Chart



How to Measure pH: Place approximately 2 table-spoons (30mL) of test water in a container and add 4 drops of pH reagent. Then, mix well and check the color of the water with the pH chart above (The color of the water will change according to its pH.)

- If the power cord is damaged, it must be replaced by the manufacturer, or a similarly qualified Tyent repair person in order to avoid a hazard.
- This appliance is not intended for use by persons (including children) with reduced physical sensory or mental capabilities or lack of experience and knowledge, unless they have been given supervision or instruction concerning use of the appliance by a person responsible for their safety.
- Children should be supervised to ensure that they do not play with the appliance.

**MADE IN KOREA**



# UNDER COUNTER EXTREME PLUS

Premium Metal Edition



## User's Manual

- This is Home appliance product.
- This product is intended for domestic use only.
- Keep this User Manual handy for easy reference.
- Carefully read this User Manual, particularly "all safety warnings."

**TO OUR VALUED CUSTOMERS**

Thank you for purchasing the UCE PLUS Series Water Ionizer. Please read all safety warnings and this User's Manual carefully before using this product to ensure proper product usage. Keep the manual handy for easy reference.

- We are not responsible for any accidents and/or malfunctions due to the improper use of this machine.
- Please keep the manual and warranty card in a safe place, so that it's easily accessible when you need it.
- Please refer to this manual often when you have questions during usage or when troubleshooting this unit.

**INTENDED USE**

This device creates functional alkaline, ionized water and water with molecular hydrogen. It changes the properties of regular tap water through the use of electrolysis. Note the following changes that normal tap water undergoes via this process:

- An increase or decrease in pH level
- Creation of negatively charged hydrogen ions (antioxidants)
- An increase in molecular hydrogen
- Purification through filtration

**TABLE OF CONTENTS**

To Our Valued Customers .....	2
Table of Contents .....	3
Before Usage .....	4
Safety Precautions and Warnings .....	6
Installation Diagram .....	11
Dispenser Overview .....	12
Ionizer Overview .....	13
Product Features .....	14
Package Contents .....	18
Under-Sink Installation .....	19
Dispenser Installation .....	20
Ionizer Installation .....	21
Customer Serviceable Parts .....	23
How to Change the Filters .....	24
How to Reset the Filter Counters .....	25
How to manage scale .....	26
Touch Screen Operation .....	27
Unit Usage .....	31
pH Level Adjustment .....	34
System Setup Method .....	35
Selecting Voice on/off .....	44
Eco Mode .....	45
Cleaning Function .....	46
Turbo Function .....	47
Usage Recommendations .....	48
Temperature Sensor .....	50
Unit Specifications .....	51
Troubleshooting .....	52
Product Warranty .....	54



## BEFORE USAGE

Safety precautions are provided for the safe and proper use of this unit and can prevent danger, bodily harm and/or possible damage due to misuse. Please make sure you are familiar with all the safety precautions and warnings associated with this unit.



**DANGER (Red Warning Sign)** indicates an imminent hazard that could result in serious injury or death. If you see this sign, stop using this unit immediately.



**WARNING (Orange Warning Sign)** indicates a potential hazard that could result in significant bodily harm or damage to the unit. If you see this sign, stop the use of this unit.



**ATTENTION (Yellow Warning Sign)** indicates a potential hazard that could result in minor bodily harm or damage to the unit.

- ① Do not drink functional water with medication. When taking medication, use "clean H<sub>2</sub>O" filtered water thirty minutes prior to taking medication as well as with medication. You may resume drinking functional water thirty minutes after taking medication.
- ② Always consult your primary care physician before drinking functional water. Start off by drinking Level 1 alkaline water for the first four weeks. Starting out slow is essential because water at higher pH levels is very healthy and cleansing, and your body needs time to adjust during the detoxification period.
- ③ If you notice any negative effects from drinking functional water, stop drinking the functional water immediately and consult your primary care physician about changes in your body's pH level.
- ④ If you are currently under the care of a primary care physician for an existing condition, consult your primary care physician about how changes in pH and other characteristics of functional water could affect your medical condition.
- ⑤ If you suffer from gastric anacidity, kidney failure or potassium excretion, you should not drink functional water.

- ⑥ Verify the pH levels of the functional water dispensed from this unit on a monthly basis to ensure proper function. This can be done with the supplied reagent drops and a pH color chart.
- ⑦ When switching from one pH to another, it is good practice to let the water run for 10-15 seconds before using.
- ⑧ It is common to drink half your body weight in ounces. For example, if you weigh 180 pounds, it may be wise to drink 90 ounces of water per day. This especially applies after you have given your body some time to adjust to the new pH level.
- ⑨ The recommended drinking level for functional water is 9.5 pH (+-0.3). It is not recommended to drink functional water above a pH of 10.
- ⑩ If you wish to store functional water, use a glass or other non-leaching material with an airtight lid and store it in the refrigerator. Functional water will begin to weaken immediately and will lose most of its benefits after 3 days.
- ⑪ Never run hot water through this unit.
- ⑫ Never drink acidic or turbo water.



**Use only source water approved as drinking water by an authorized organization (i.e. tap water).**

- If using groundwater, make sure the water meets drinking water compliance standards before installation. If not, a pre-filter may be required. (source water quality greatly affects pH values and filter performance)
- **DO NOT** use excessively hard water or saltwater. (may cause malfunctions and/or shorten the product life)
- **DO NOT** use extremely hard water, or water that contains a lot of sediment, or that has very high TDS level without first consulting Tyent USA in order to determine if a pre-filter is needed.

**SAFETY PRECAUTIONS AND WARNINGS**

This appliance is not intended for use by persons (including children) with reduced physical, sensory or mental capabilities, or lack of experience and knowledge, unless they have been given supervision or instruction concerning use of the appliance by a person responsible for their safety. Children should be supervised to ensure that they do not play with the appliance.

**Regarding the Power Supply**



Do not use if the power cord is damaged or in a loose power outlet.



Never touch the power cord or the power outlet with wet hands.



Do not forcibly bend, squeeze, damage or crush the power cord under heavy objects.



Unplug the power cord during general maintenance, repair and inspection and while replacing parts.



Do not use power surge protectors with this unit. Use the unit with its own dedicated power source.



Only use the unit with the correct voltage.



To reduce the risk of electric shock, do not remove the cover; there are no user-serviceable parts inside. Refer servicing to qualified service technician. Removing the cover will void the warranty.



**Installation**



Do not place this unit near heat sources.



Do not use unfit raw water in accordance with the standards of the water service act.



Do not use in areas of high humidity and/or high temperature.



Do not place this unit on an uneven surface. Do not drop or use excessive force on this unit.



Do not connect the water line to a hot water supply. Please use a new hose to connect to the water line. (Do not reuse an old hose as it can cause leakage.)



new hose





If the unit is not used for a few days, let the water run for 1-2 minutes before drinking functional water.



Do not run the water for longer than 1 hour.



**Usage**



If the unit won't be used for a long time, shut off the valve and unplug the power cord.



If you hear strange noises, smell a burning odor or see smoke, unplug the power cord immediately and call qualified personnel for service.



Replace filters every 6 months to optimize the purification performance of this unit even if the replacement indicator light isn't turned on.



Do not place any objects on top of this unit no matter how small they are.



If water leaks out of the unit (other than the hoses) or if the unit is standing in a puddle of water, shut off the water supply, unplug the power cord and contact qualified service personnel for service.



Do not use or store pH reagents near flame. (There is a risk of fire)



It is beneficial for the maintenance of the machine to run a strong acidic level for 5minute cycles twice weekly. This will help to maintain a clean chamber.

※ When you use the Water ionizer in areas with very hard water, please run Acidic level 3 for a minute every day.



Do not poke or scratch the touch pad or LCD display with sharp objects.



In areas of hard water (where calcium scaling is present on faucets), notify your service provider and install a cell safe anti-scale pre-filter to protect the ionizer from scale build-up.



Do not use alkaline or acidic water in fish bowls or aquariums. The sudden change in pH could be harmful or fatal to some marine life.



It is normal for condensation to be present on the unit during humid summer months. If condensation persists despite weather conditions, unplug the power cord and refer servicing to qualified service personnel.



**Cleaning**



Do not store the unit near chemicals, food, metals or medication



Do not spray water on the main unit. Do not clean the unit with chemicals such as benzene or thinner, which may leak into the unit. If using a damp cloth, be very careful not to get the electronic display wet.



**Danger: Do not use benzene or thinner!**



Please clean the inside and outside of the outlet pipe with a soft brush [If you do not clean it regularly, scale, such as lime components (Calcium and Magnesium)] may occur.



In areas with high TDS of water, calcium can remain in the tip of the outlet pipe. Please keep it clean.



**Storage**



Remove the filters and turn them upside down to remove the excess water before storing.



If the original packaging is not available, then store in a cool dry place where the unit won't be scratched.



Carefully remove this unit from its packaging. Keep the original packaging for future storage and unit transportation. When not in use, store the unit in its original packaging, without the plastic bag, in a cool, dry place.



**INSTALLATION DIAGRAM**

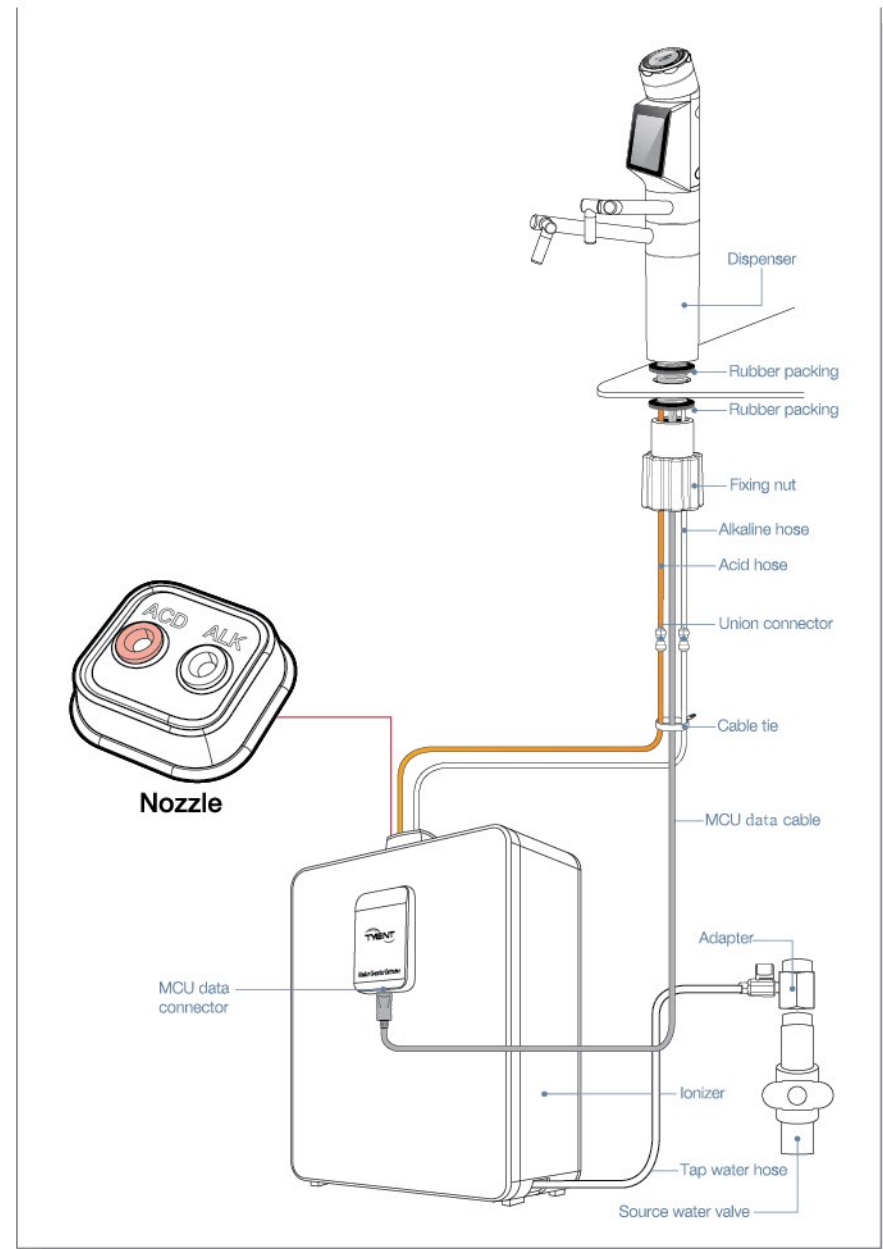

DISPENSER OVERVIEW

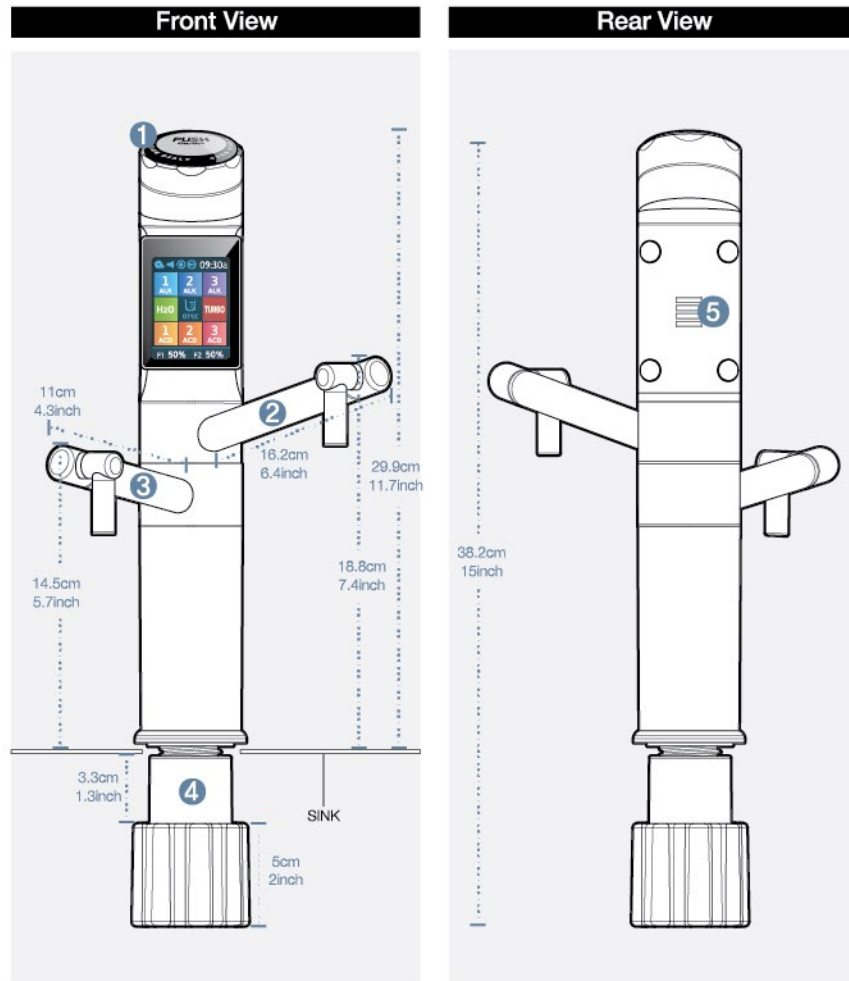

- ① Jog Dial
- ② Water Outlet Pipe
- ③ Drain Pipe
- ④ Fixing Nut

- ⑤ Speaker

IONIZER OVERVIEW

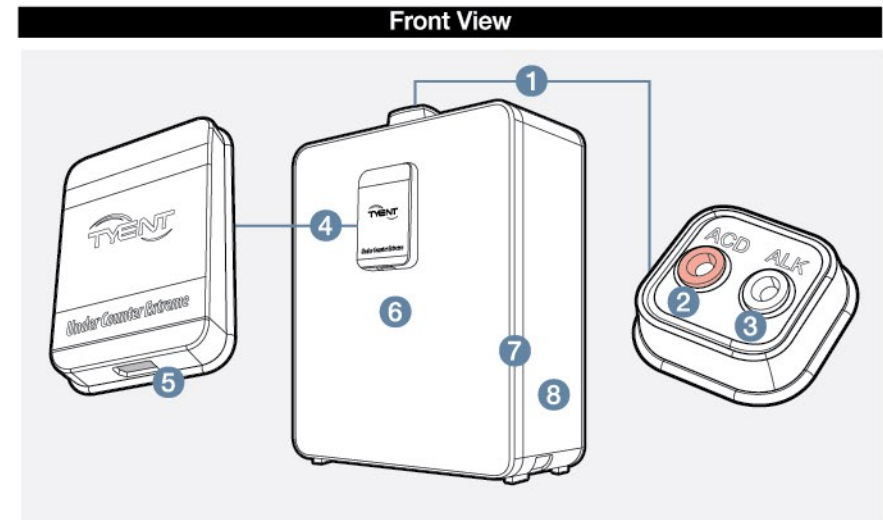

- ① Nozzle
- ② Acidic Outlet
- ③ Alkaline Outlet
- ④ Front cover
- ⑤ Cable Connector
- ⑥ Front Sheet
- ⑦ Door Case
- ⑧ Front Case

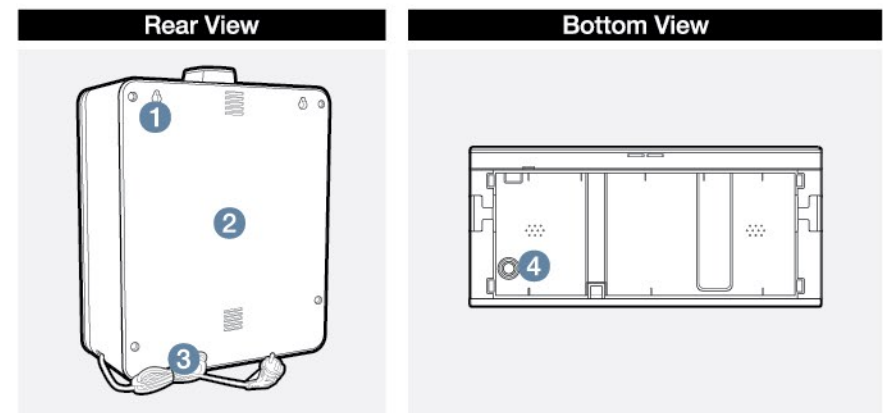

- ① Hanging Groove
- ② Rear Case
- ③ Power Cord

- ④ Water Inflow



PRODUCT FEATURES

A DESIGN MASTERPIECE



Offering both Kitchen Space and Ultimate Beauty

The **TYENT Under Counter Extreme PLUS** Water Ionizer not only attracts person's gaze with its well-differentiated appearance, but also helps to upgrade your kitchen's interior decoration with a neat and luxurious expression.

FULL TOUCH LCD – TRANSFORMATION AT YOUR FINGERTIP



The Industry's First Full Touch Screen Panel

The Full Touch Screen Panel System automatically activates the unit's operations through a simple touch to the desired icon displayed on the screen.



Touch LCD Screen with a Clear Picture Tone

A 262,000 Color Touch LCD Display provides diverse information in true vivid colors for user convenience.



GUI [Graphical User Interface]

A Graphical User Interface is designed specifically for ease of use and operation. Communication between the user and ionizer has never been this simple!

JOG DIAL & TOUCH



Jog Dial & Touch with 2 way Operation Compatibility

Choose from either the Jog Dial or the Touch Screen Panel system—both are available with 2 way operation compatibility and are easy to use at your convenience.

MORE POWERFUL SYSTEM ENGINE !



Upgraded Power Turbo System

The upgraded Turbo SMPS Plus Power Supply system produces strong Turbo acidic and strong Turbo alkaline pH levels for many uses! See Tyent's USES guide for more information.

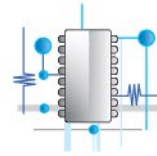

SMPS Plus Power Supply System

SMPS Plus Power Supply System provides the maximum instantaneous output needed to produce the highly stable electric power required for each phase of electrolysis.



Electrodes with Solid/Mesh Hybrid Plate Technology

These Platinum-Coated Titanium Plates are made with highly stable, durable Solid/Mesh Hybrid technology that enhances the instantaneous electrolysis efficiency.

CAREFUL CONSIDERATION FOR THE USER



Fixed quantity discharge function

For your convenience, the ionizer has the ability to dispense a predetermined amount of water and then stop. Presets include 0.5L, 1.0L & 1.5L. These presets can be further adjusted with the jog dial.



Easily identify water discharging level by LCD screen and color

Each pH levels have their own color and screen. It will be changed LCD screen and Jog Dial light though you select functional level.



Excellent MP3 Sound Quality with Guided Support

Operating functions can be further identified by the voice guided system.





**Multiple Languages Supported**

Diversified language guide support is available by selecting the languages featured from across the world.



**Temperature Sensor Function for Safe Operation**

If the temperature of the source water exceeds 95°F (35°C) then the water will stop flowing and a warning message will appear on the screen.



**Automatic Water Discharge Interruption Function**

In order to prevent the overflow of water in case of user negligence, the water discharge will automatically stop after 15 minutes of use. **(\*TURBO: 5 minutes)**



**Automatic Electrolysis Tank Cleaning Function**

The interior of the Electrolysis Tank is automatically cleaned on a regular basis, ensuring stable electrolysis operating conditions.



**Automatic Memory Function**

The last function used by the user is automatically memorized and displayed on the Standby Screen for fast and convenient operation.

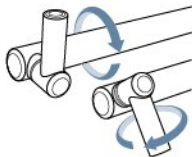

**Water Discharge Nozzle with Directional Control**

The water discharge direction may be adjusted to many diverse angles based on user preference.

**CARE FOR THE ENVIRONMENT**



**Earth-Friendly Technology when in ECO Mode**

True energy saving is accomplished with ultra low power consumption during periods of non-use.

**FRESH, PURIFIED WATER WITH HEALTHY MINERALS IS A MUST!**



**Water Purification Through a Clean Process**

Perfect, seamless elimination of foreign substances including residual chlorine, organic & inorganic compounds through the filtering process using functional UF and [ ] Ceramic materials, enhancing the alkaline water producing condition.

**SELF MAINTENANCE MADE EASY - FROM INSTALLATION TO POST-SERVICE**



**Filter Usage Indication and Replacement Time Guide**

The level of filter usage can be identified through the LCD Screen on a real time basis. The recommended replacement time is automatically displayed on the screen with a voice guide.



**Super Simple Filter Replacement System**

A simple filter replacement system along with a one-touch Filter Usage Initialization Setting System makes filter management easy for anyone.



**Customizable Settings System**

For your convenience, the LCD screen allows you to easily customize all of your favorite settings.



**pH Control Function**

Respective alkaline, acid & turbo phases can be easily controlled by the user.



**Self Diagnosis Function**

When the condition of the source water is not suitable, the water discharge is automatically suspended, displaying a Warning Sign on the screen.

 Picture of components can be different from the real ones, and some items may be changed according to advancements in technology.

PACKAGE CONTENTS

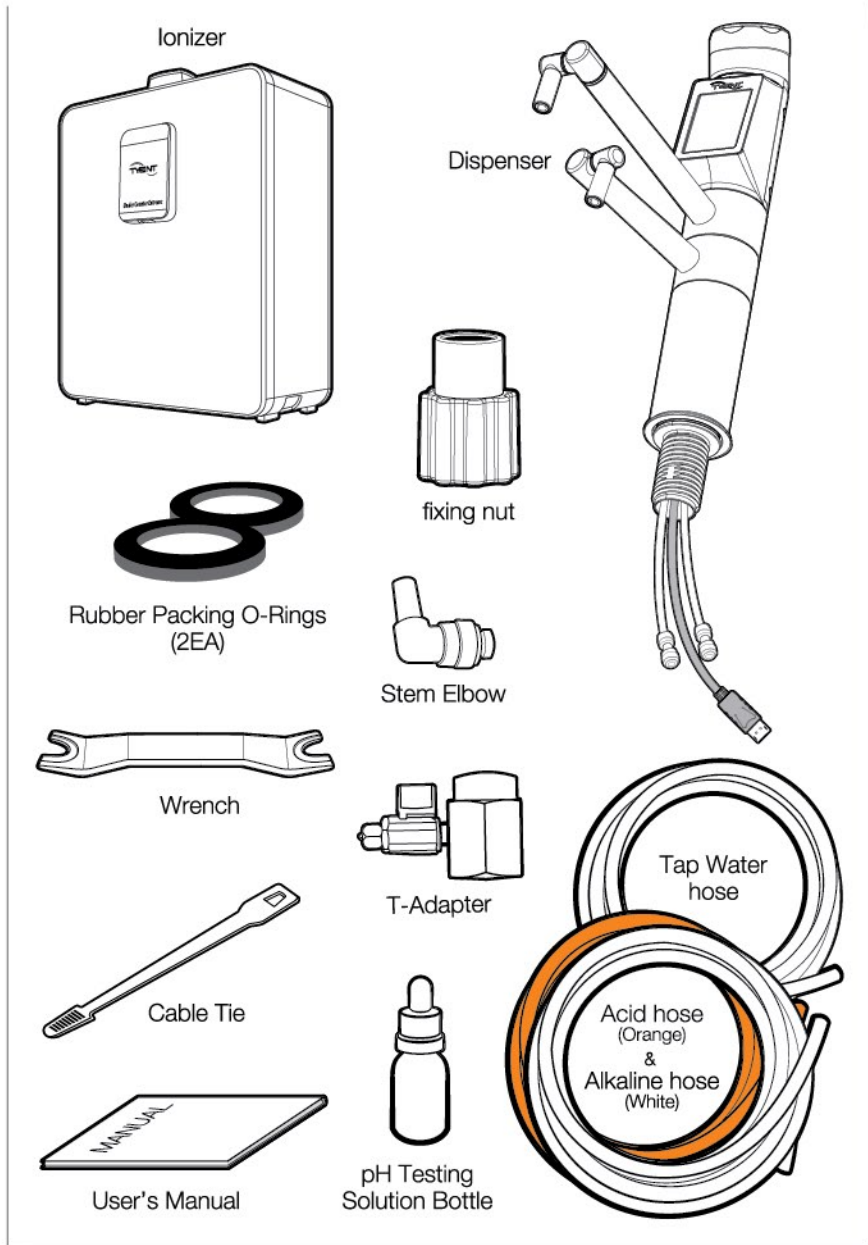

UNDER-SINK INSTALLATION

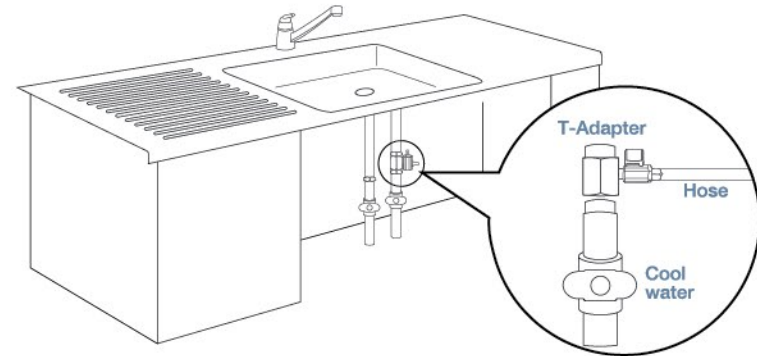

1. Shut off both the hot and the cold water main supply at the pipe under the sink.
2. Locate the cold water supply line valve.
3. Disconnect the faucet's cold water supply line from the main cold water pipe. Use a towel to catch the small amount of water that may come from the faucet supply line.
4. When connecting the T-Adapter to the cold water pipe, be sure to use plumber's tape or teflon tape (not included) to prevent leaks.
5. Reconnect the faucet's cold water supply line to the T-Adapter (now secured to the main cold water pipe).
6. Be sure all connections are secure, but do not overtighten them.

※ Do not turn on the main water supply until all hoses are properly installed to the unit.  
 ※ The unit and components are subject to change without prior notification in order to enhance performance.

## DISPENSER INSTALLATION

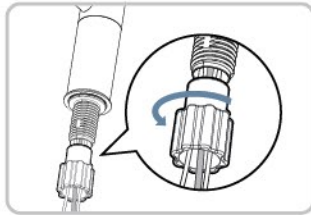

- ① First, unscrew the large nut from the bottom of the dispenser.

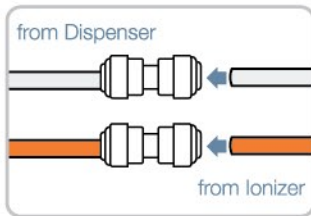

- ② Connect each hose from the dispenser to a union connector. Connect each hose from the ionizer to the union connector. When you connect the hoses, please match the hoses by color: i.e., orange–orange, white–white

※ If your tower has hoses that are red and clear instead of orange and white, then connect the red hose to the orange hose and the clear hose to the white hose.

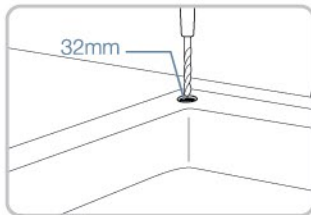

- ③ Use a 32mm(1 1/4 inch) drill bit to drill a hole.

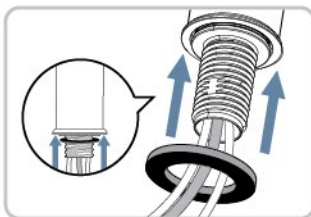

- ④ Insert one of the provided rubber O-Rings in the assembled dispenser.

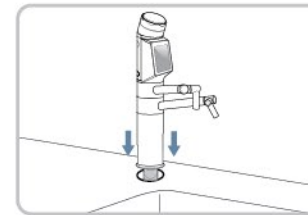

- ⑤ Place the assembled dispenser into the drilled hole.

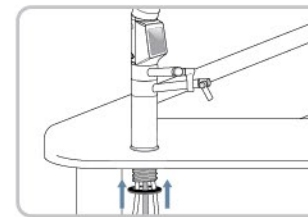

- ⑥ Insert the second rubber O-ring in the assembled dispenser located underneath the sink.

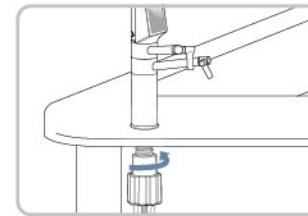

- ⑦ Tighten the fixing nut underneath the sink. (do not over-tighten)

## IONIZER INSTALLATION

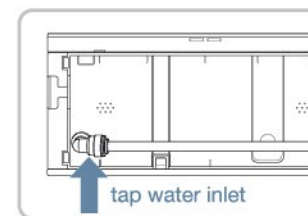

- ① Connect the cold water supply hose to the tap water inlet on the underside of the ionizer using the supplied stem elbow.



## IONIZER INSTALLATION

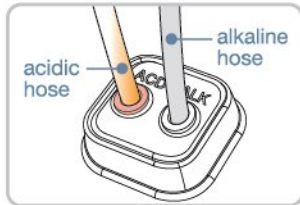

② Connect Alkaline Hose and Acidic Hose to the Nozzle on the top of the water ionizer body.

※ Be sure to connect the hose correctly as indicated on the Nozzle.

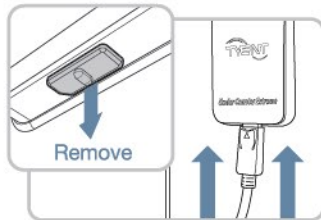

③ Connect the Faucet MCU data cable to the cable connector.

※ before connecting the MCU data cable, please remove the cap which connected to the cable connector.

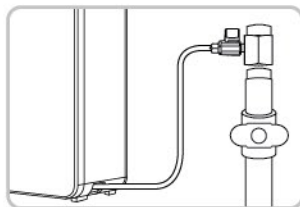

④ Connect the hose from the inflow hole to the cold water supply at the under-sink T-Adapter. Make sure all hose connections are firmly seated in the correct holes, both on the unit and at the water supply.

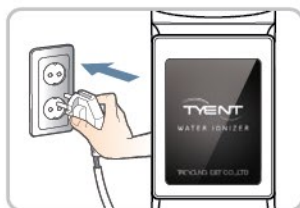

⑤ Plug in the power cord and turn on the unit.

※INTRO Screen appears only when Initial Power is supplied.

## CUSTOMER SERVICEABLE PARTS

**ATTENTION:** If you do not use the TYENT original filter or parts for replacement, it will cause product malfunction, and it will void your warranty.

**\*If you do not use TYENT original filters, the following problems will occur:**

- Your warranty will be voided.
- It may cause product leakage.
- It may cause product malfunction.
- Filter performance is significantly reduced.
- The life of the product is shortened.



Primary Filter: **1st Filter**

**Recommended filter replacement cycle:**  
(Every 6 months)

Removes harmful chemicals like chlorine, compounds such as agrichemicals and detergents, large suspended matters like rust and sediments as well as other volatile organic compounds through an efficient activated absorption method. It also eliminates bad smells and any remaining dissolved chlorine.



Secondary Filter: **2nd Filter**

**Recommended filter replacement cycle:**  
(Every 6 months)

Fine artificial film filters contaminated materials including ordinary bacteria while maintaining essential minerals in the water.

The life of the filter can vary greatly due to use, water pressure, water quality and the changing of the seasons. Filters may need to be replaced sooner than the scheduled time due to these reasons, and you may notice reduced water quality or declining water taste.

## HOW TO CHANGE THE FILTERS

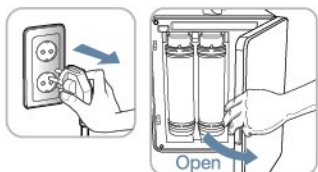

① Shut off the water supply to the unit and unplug the power cord. Open the door in front of the ionizer that's located underneath your sink.

※ Be sure to keep the ionizer upright while changing the filters. Do not lay the unit down!

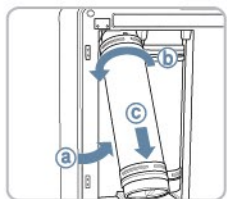

② Remove old filter:

- Ⓐ Lift the filter that needs to be replaced.
- Ⓑ Turn the filter counterclockwise until it loosens.
- Ⓒ Pull the filter down and remove it.

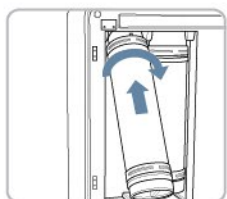

③ Put the new filter into the right position by turning it clockwise.



④ When installing the filter, the connection bump of the head and the connection groove on the top of the filter should be completely combined.

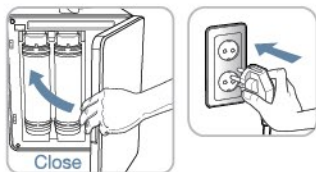

⑤ Close the door, plug the power cord back in and reengage the water supply.

After initializing the filter, press the H<sub>2</sub>O button and run purified water for 3 minutes. It is highly recommended that you follow this process in order to ensure that your machine functions properly.

## HOW TO RESET THE FILTER COUNTERS

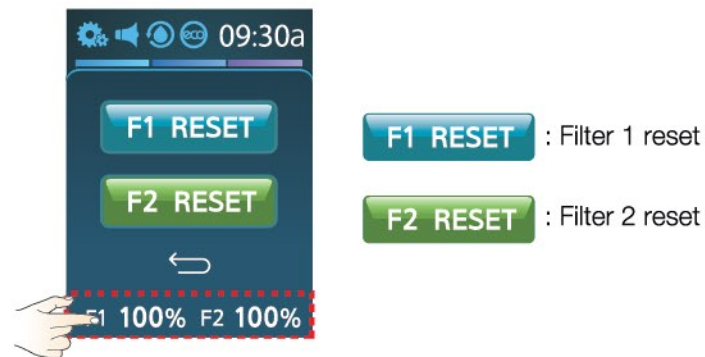

### 1. First Filter Reset

- ① Press the bottom part of the LCD screen. A menu will appear on the LCD screen.
- ② To initialize, press the F1 RESET icon 2 times. The ionizer will speak and say "First Filter" then "Initializing was performed" and F1 percentage will go back to 00%.

### 2. Second Filter Reset

- ① Press the bottom part of the LCD screen. A menu will appear on the LCD screen.
- ② To initialize, press the F2 RESET icon 2 times. The ionizer will speak and say "Second Filter" then "Initializing was performed" and F2 percentage will go back to 00%.

※ If you do not initialize the filter after replacing the filter, the corresponding filter change message will continue to operate.

※ After initializing the reset, press the H<sub>2</sub>O button and run purified water for 3 minutes.

## HOW TO MANAGE SCALE

- ※ For safe water ionizer use, use a citric acid filter or scale remover regularly to manage scale that can occur in the water cell.
- ※ If scale continuously accumulates in the water cell, it may decrease ionizer performance or cause malfunctions.

**TYENT scale management products**  
(separately purchased product)



**TYENT Citric acid filter**

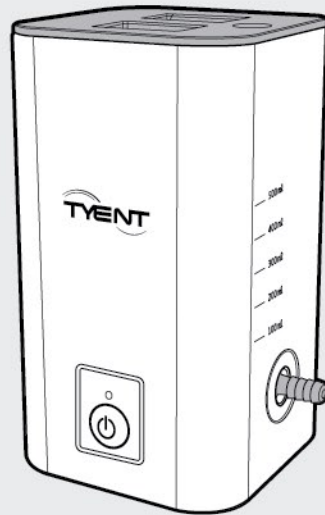

**TYENT Scale Remover**

## OPERATION TOUCH SCREEN

### 1 Standby mode



● Display line of the set status

● Functional water operation

● Display line of filter usage ( default : 00% )

### ICON : Description

	System Setup		Alkaline level 1
	Voice on		Alkaline level 2
	Voice off		Alkaline level 3
	Cleaning		Purified water
	Eco mode on		Turbo water
	Eco mode off		Acidic level 1
<b>F1, F2</b>	Filter usage		Acidic level 2
	Fixed qty discharge		Acidic level 3



## 2 Menu window

Push the upper part of LCD Screen. MENU Window appears below the upper part of LCD Screen.

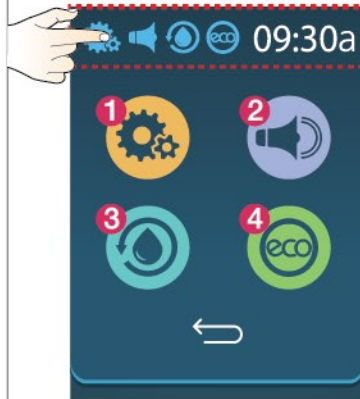

-  ① Set up mode
-  ② Voice on/off
-  ③ Cleaning
-  ④ Eco mode on/off

Push the bottom part of LCD Screen. MENU Window appears above the bottom part of the LCD Screen.

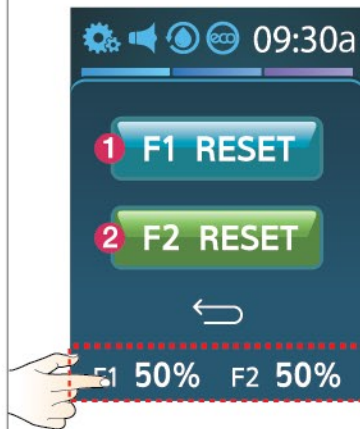

-  ① Filter 1 reset
-  ② Filter 2 reset

**CAUTION!** Use the Filter Initialization Icon only after the filters have been changed.

## 3 LCD Display



- Alkaline 1** Selected mode
- Display the outflow level image
- 2.5 L/min Rate of water inflow
- 14:59 Remaining discharge time
- When setting quantitative output : It displays the current amount of outflow and counts up to the set quantity.  
**0.50 l**

### DISPLAYS COLORS

The backlight of the LCD display will match the pH level color according to the water pH level being used after the icon is pressed.

							
2.5 L/min   14:59	2.5 L/min   14:59	2.5 L/min   14:59	2.5 L/min   14:59	2.5 L/min   14:59	2.5 L/min   14:59	2.5 L/min   14:59	2.5 L/min   04:59
Alkaline Water 1 (Approx 8.0 pH) Light Blue Color	Alkaline Water 2 (Approx 8.0 pH) Dark Blue Color	Alkaline Water 3 (Approx 10.0 pH) Purple Color	Acidic Water 1 (Approx 6.5 pH) Light Yellow Color	Acidic Water 2 (Approx 4.5 pH) Light Orange Color	Acidic Water 3 (Approx 3.5 pH) Light Pink Color	Clear Water (Approx 7.0 pH) Green Color	Turbo Red Color

#### 4 Message Display

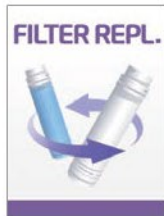

When the screen above appears (or pops up), the filter needs to be replaced.



This display means that the water outflow has been stopped prior because of the suspension of water supplied to the unit.



When the inflow water is higher than 95 °F (35 °C), this screen will pop up. The unit will stop the outflow automatically.



This warning message will appear when the unit reaches the automatic cleaning time.



This cleaning message will appear when the unit is being cleaned, which will happen automatically. You can also clean the unit manually if desired or needed.

#### CAUTION: Touch Screen Use

1. Due to the uniqueness of the TOUCH Screen, TOUCH is not recognized if pushed by more than one finger. Please push with only one finger and be careful of contamination to the screen that may cause damage to the TOUCH.
2. Be careful of electrostatic materials near the TOUCH Screen. Stimulation from such materials may cause damage to the TOUCH.
3. The screen may not be seen well under direct sunlight.
4. Do not push the Screen hard with sharp or pointy objects.

#### UNIT USAGE

##### 1 When using the TOUCH Screen

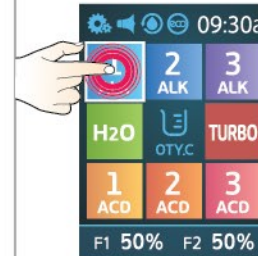

1 Press the desired icon on the LCD screen

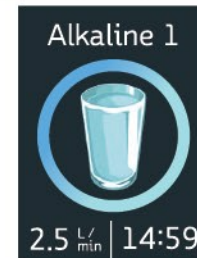

2 The water outflow will start, and the screen will display the current level and stop time.

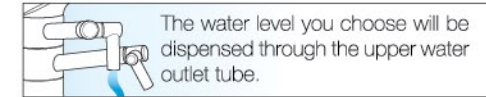

3 Press the screen to stop the flow of water.

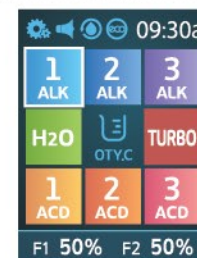

4 When done, the screen will move to the last icon that was used and go into stand-by mode.

## 2 When using the JOG DIAL



- 

Turn the jog dial in either direction to select the desired function. The white highlight signals which function is selected.



- 

When the screen changes to the selected color, push the center of the dial to start the water outflow.

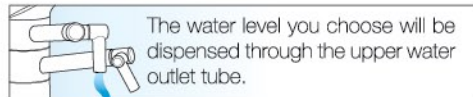

- 

Push the center of the dial to stop the water outflow.



- When finished, the screen will move to the last icon that was used and go into stand-by mode.

## 3 When using fixed quantity discharge function

### When using the Touch Screen



- Touch the QTY.C icon and choice the fixed amount of water.  
(0.5 > 1.0 > 1.5 > release)
- Select a desired water mode.
- Water outflow stops automatically.  
(Fixed quantity discharge function is released after water comes out)

### When using the JOG DIAL



- Touch the QTY.C button.
- Select the fixed amount of water that you need by turning the jog dial.
  - Clockwise: Increasing by 100ml (Max.5L)
  - Counterclockwise: Decreasing by 100ml (Min.200ml)
- Push the discharge level that you need.
- Automatic stop after discharging the fixed amount of water that you selected.  
(Discharge of water will stop if you press the button again during water discharge.)
- After the water discharge completes, the fixed quantity function is released.



## pH LEVEL ADJUSTMENT

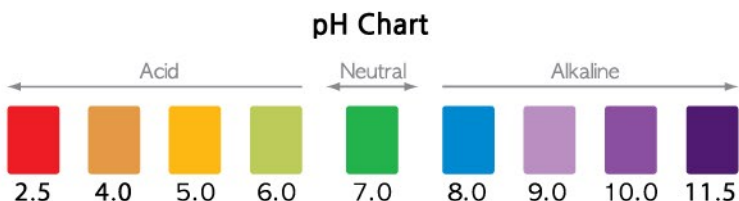

When testing the pH, be sure to allow the unit to run for 1 minute (60 seconds) before taking a sample of the water. If you have to adjust the percentage, after adjusting, run for an additional 1 minute before taking a new sample. When testing pH values, we like to use 2 tablespoons (30mL) of the water being produced and 4 drops of the reagent in a clear glass. The minimum and maximum Turbo waters produced will depend on the water source quality. Set Turbo at 99% for maximum pH levels. These levels can range normally as follows:

### Color of pH testing of each level:

- Alkaline Turbo (dark purple)
- Acidic Turbo (red)
- Alkaline Level 1 Approx. 8.0-8.5 pH (light blue)
- Alkaline Level 2 Approx. 9.0 pH (light purple)
- Alkaline Level 3 Approx. 9.5 pH (purple)
- H2O = Approx. 7.0 pH (green) Purified Water
- Acid Level 1 Approx. 6.5~5.5 pH (light greenish yellow)
- Acid Level 2 Approx. 5.5~4.0 pH (light orange)
- Acid Level 3 Approx. 4.5~3.5 pH (dark orange)

※ The pH value indicated for each level is based on standardized test results which have used average tap water.

## SYSTEM SETUP METHOD

### 1 ALKALI pH Level Adjustment



1 Press the top left corner of the screen. MENU options will fall below upper part of screen.

2 Press the setup icon.



3 Press "ALKALI pH"

#### When using the Jog Dial



Turn the Jog Dial clockwise (or counter-clockwise) to select "ALKALI pH". Press the PUSH On/Off button of the jog dial to make your selection.

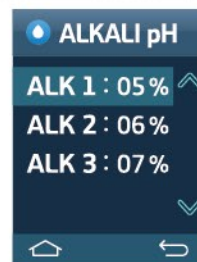

4 Press desired level.

5 or : ALK pH level up (05%, 06%, 07%...)

or : ALK pH level down (04%, 03%, 02%...)

※ With the desired level highlighted press to raise the percentage of power or press to lower the percentage of power for that level. Pressing either arrow once will change the value by 1% in that direction. Holding the arrow will cause the percentage to change continuously until the arrow is released.

#### Backcolor

- This color highlight shows the current position on the menu.
- This color highlight means that changes to that setting are possible.



Push RETURN icon for previous menu screen. Voice says: "Applied"  
Push RETURN icon again to complete set up.  
Voice says: "Set up was completed"

※ VALUES SHOWN ARE EXAMPLES ONLY AND ARE NOT TO BE TAKEN LITERALLY

## 2 Acidic pH Level Adjustment



- 1 Press the top left corner of the screen. MENU options will fall below upper part of screen.
- 2 Press the setup icon.



- 3 Press "ACIDIC pH"

### When using the Jog Dial



Turn the Jog Dial clockwise (or counter-clockwise) to select "ACIDIC pH". Press the PUSH On/Off button of the jog dial to make your selection.

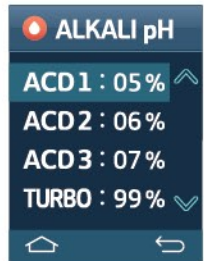

- 4 Press desired level.
- 5 or : ACD pH level up (05%, 06%, 07%...)  
 or : ACD pH level down (04%, 03%, 02%...)

※ With the desired level highlighted press to raise the percentage of power or press to lower the percentage of power for that level. Pressing either arrow once will change the value by 1% in that direction. Holding the arrow will cause the percentage to change continuously until the arrow is released.

### Backcolor

- This color highlight shows the current position on the menu.
- This color highlight means that changes to that setting are possible.



Push RETURN icon for previous menu screen. Voice says: "Applied"  
 Push RETURN icon again to complete set up.  
 Voice says: "Set up was completed"

※ VALUES SHOWN ARE EXAMPLES ONLY AND ARE NOT TO BE TAKEN LITERALLY

## 3 LANGUAGE Mode



- 1 Press the top left corner of the screen. MENU options will fall below upper part of the screen.
- 2 Press the setup icon.



- 3 Press "LANGUAGE"

### When using the Jog Dial



Turn the Jog Dial clockwise (or counter-clockwise) to select "LANGUAGE". Press the PUSH On/Off button of the jog dial to make your selection.



- 4 Press desired language.

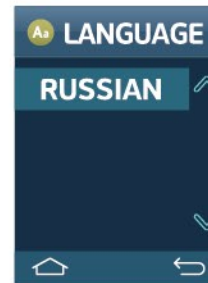

### When using the Jog Dial



Turn the Jog Dial clockwise (or counter-clockwise) to select your desired language.



Push RETURN icon for previous menu screen. Voice says: "Applied"  
 Push RETURN icon again to complete set up.  
 Voice says: "Set up was completed"

### 4 Volume Level Adjustment



- 1 Press the top left corner of the screen. MENU options will fall below upper part of the screen.
- 2 Press the setup icon.



- 3 Press "VOLUME"

**When using the Jog Dial**



Turn the Jog Dial clockwise (or counter- clockwise) to select "VOLUME". Press the PUSH On/Off button of the jog dial to make your selection.

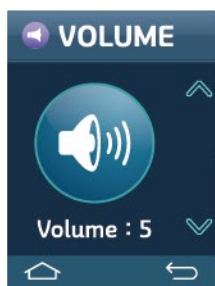

- 4 or : Volume up (0- 10 step)  
 or : Volume down (0- 10 step)



Pressing the Push On/Off button on jog dial will let you hear the current volume.



Pressing this icon will let you hear a sample of the voice at the current volume.



Push RETURN icon for previous menu screen. Voice says: "Applied"  
 Push RETURN icon again to complete set up. Voice says: "Set up was completed"

### 5 Setting the TIME



- 1 Press the top left corner of the screen. MENU options will fall below upper part of the screen.
- 2 Press the setup icon.



- 3 Press "TIME"

**When using the Jog Dial**



Turn the Jog Dial clockwise (or counter- clockwise) to select "TIME". Press the PUSH On/Off button of the jog dial to make your selection.



- 4 Adjustment time and date with the arrows :  
 Ⓐ Year    Ⓑ Month  
 Ⓒ Day     Ⓓ Hour  
 Ⓔ Minute

**Backcolor**

- This color highlight shows the current position on the menu.
- This color highlight means that changes to that setting are possible.



- 5 or : for Up    or : for Down

Time set up is complete.



Push RETURN icon for previous menu screen. Voice says: "Applied"  
 Push RETURN icon again to complete set up. Voice says: "Set up was completed"



## 6 SLEEP Mode Setting



- 1 Press the top left corner of the screen. MENU options will fall below upper part of the screen.
- 2 Press the setup icon. 

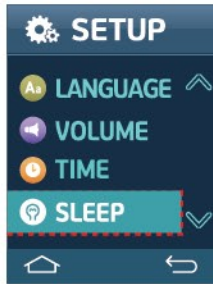

- 3 Press "SLEEP"

### When using the Jog Dial



Turn the Jog Dial clockwise (or counter-clockwise) to select "SLEEP". Press the PUSH On/Off button of the jog dial to make your selection.

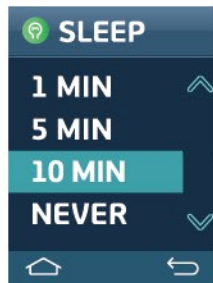
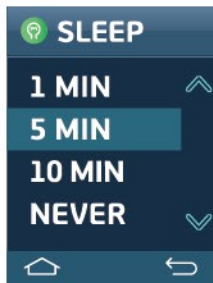



- 4 Set the Sleep mode timer to your preferred time.  
 ※ Power save mode is enabled when not in use.

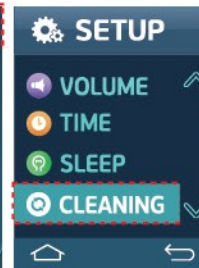

Push RETURN icon for previous menu screen. Voice says: "Applied"  
 Push RETURN icon again to complete set up. Voice says: "Set up was completed"

## 7 CLEANING Mode Setting



- 1 Press the top left corner of the screen. The menu options will fall below the upper part of the screen.  
 Press the setup icon. 
- 2 Press **CLEANING**.

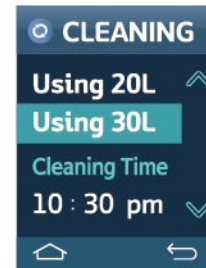

- 3 You can choose to have the automatic cleaning occur after a predetermined volume of water is poured, or you can choose to have the cleaning cycle run at a certain time of the day.

※ **Note:** The actual cleaning cycle will not start on its own. Instead, the unit will wait until the next time that you use the machine, and it will be begun by pressing the screen or jog dial. To set a time for cleaning, touch the current set time and use the up and down arrows to make adjustments.

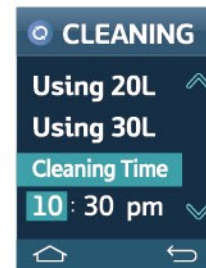

- 4 Select **CLEANING TIME**.

※ You can set up the cleaning cycle as a time.  
 ※ Automatically enters the cleaning mode at the set time every day.  
 ※ To set a time for cleaning touch the hour or minutes and use the up and down arrows to make adjustments.



Push RETURN icon for previous menu screen. Voice says: "Applied"  
 Push RETURN icon again to complete set up. Voice says: "Set up was completed"

## 8 MAIN Display Setting

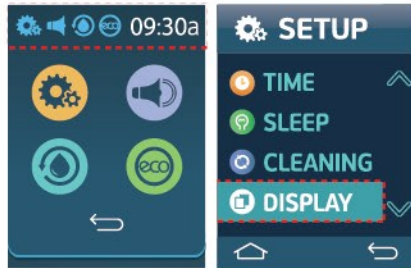

- 1 Press the top left corner of the screen. The menu options will fall below the upper part of the screen.

Press the setup icon.



- 2 Press **DISPLAY**.

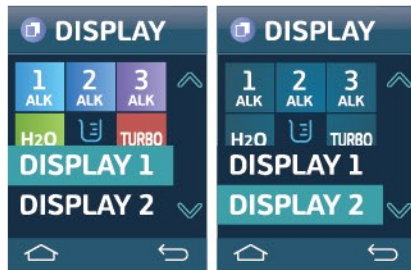

- 3 One of the two main display designs can be set as a main.



- 4 The display appearance you select will be reflected when you return to the home screen.



Push RETURN icon for previous menu screen. Voice says: **"Applied"**  
Push RETURN icon again to complete set up. Voice says: **"Set up was completed"**

## 9 TOUCH Calibration

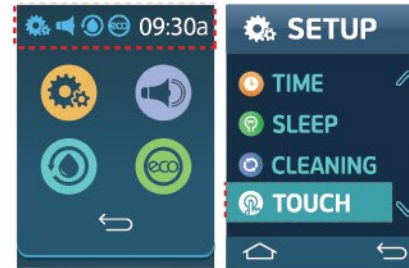

- 1 Press the top left corner of the screen. The menu options will fall below the upper part of the screen.

Press the setup icon.



- 2 Press **TOUCH**.

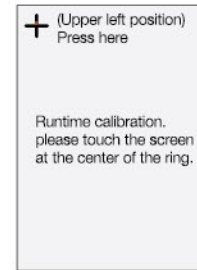

- 3 Each time a crosshair appears on the screen, touch the center of it with your finger to complete calibration.

※ Do not press with sharp or pointy objects.

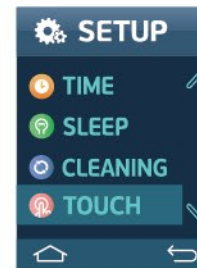

- 4 Once calibration is complete, the display will move to the setting mode automatically.

ECO Mode is a feature for saving power consumption during periods of non-use.

## SELECTING VOICE ON/OFF



- 1 Press the top left corner of the screen. The menu options will fall below the upper part of the screen.



- 2 Select the **VOICE** icon.

※ Even if the volume is turned off, warning notifications will still play through the speaker if necessary. (filter replacement, water not supplied, TEMP, cleaning, setup mode).



- 3 The voice will be turned on/off by selecting the voice icon in this sequence.



- ※ If voice function is already on, then pressing the voice icon will turn it off.
- ※ If voice function is already off, then pressing the voice icon will turn it on.

## ECO MODE



- 1 Press the top left corner of screen. MENU options will fall below upper part of screen.



- 2 Select the **ECO** icon.

- 3 Turn on/off ECO Mode by selecting the ECO icon in this sequence.

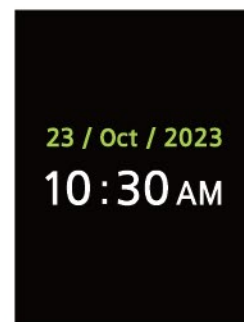

- 4 When ECO Mode is active, the unit consumes less power by going to sleep when not in use and displaying the time. The period before the unit goes to sleep if ECO is active is set under SLEEP in System Settings.

- ※ If ECO function is already on, then pressing the Eco icon will turn it off.
- ※ If ECO function is already off, then pressing the Eco icon will turn it on.



User may manually clean the unit whenever desired.

## CLEANING FUNCTION

Cleaning can take place automatically and/or manually.

- **Auto Cleaning** : Auto cleaning can be set to happen after a set amount of outflow, 20L or 30L or every 24 hours at a time of your choosing. For more information, see Cleaning Mode Settings on Page 41.
- **Manual Cleaning** : is performed whenever desired by simply touching the  icon.

### Auto Cleaning

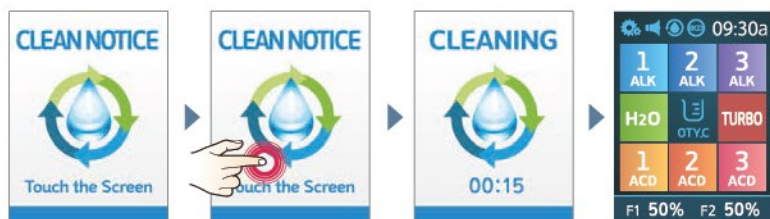

- 1 Cleaning notice screen is touched, Cleaning mode starts.
- 2 Cleaning mode stops after 15 seconds and the screen changes to the home screen.

### Manual Cleaning



- 1 Press the top left corner of the screen. The menu options will fall below the upper part of the screen.
- 2 Press the CLEANING icon. 
- 3 Cleaning mode stops after 15 seconds and the screen changes to the home screen.

## TURBO FUNCTION

The TURBO function allows you to create strong alkaline and strong acidic water. These types of waters are ONLY to be used for cleaning, sanitizing, and disinfecting purposes. **NEVER DRINK THESE TYPES OF WATER.**

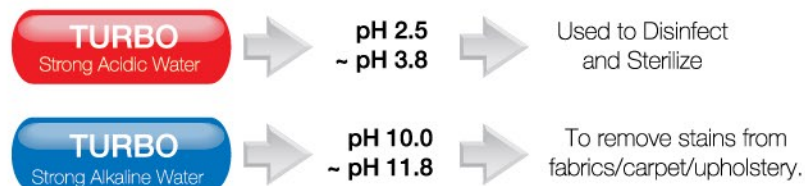

Alkaline Turbo Water Outflow



Acidic Turbo Water Outflow

### CAUTION!

The waters produced in TURBO mode are not intended for drinking.  
DO NOT DRINK these types of waters.  
DO NOT Use the TURBO function in a manner other than directed.

※ The sanitation, sterilization and disinfecting power of the water depends on your source water. Be sure to check the pH of your source water to determine if it's in the correct pH for these uses.

USAGE RECOMMENDATIONS

Alkaline 1



2.5 L/min | 14:59

Light Alkaline Water  
(Drinking Level 1)  
Approx 8.0 pH

Suitable for initial stage of drinking.

Alkaline 2



2.5 L/min | 14:59

Medium Alkaline Water  
(Drinking Level 2)  
Approx 9.0 pH

For making coffee, tea and for watering plants.

Alkaline 3



2.5 L/min | 14:59

Strong Alkaline Water  
(Drinking Level 3)  
Approx 10.0 pH

For washing vegetables, dishes and making rice.

Purify Water



2.5 L/min | 14:59

Clean Water  
Approx 7.0 pH

Creates purified water.  
For taking medications and making baby formula.

Acidic 1



2.5 L/min | 14:59

Light Acidic Water  
(DO NOT DRINK)  
Approx 5.5 pH

For washing hands and face.  
\*DO NOT DRINK.

Acidic 2



2.5 L/min | 14:59

Medium Acidic Water  
(DO NOT DRINK)  
Approx 4.5 pH

For washing vegetables and fruits.  
\*DO NOT DRINK.

Acidic 3



2.5 L/min | 14:59

Strong Acidic Water  
(DO NOT DRINK)  
Approx 3.5 pH

For washing dishes.  
\*DO NOT DRINK.

Turbo



2.5 L/min | 04:59

TURBO Function

**DO NOT DRINK.** Strong acid / alkaline water that must be used when cleaning, disinfecting, washing and sterilizing.

\* The sanitation, sterilization and disinfecting power of the water depends on your source water. Be sure to check the pH of your source water to determine if it's in the correct pH for these uses.

## TEMPERATURE SENSOR

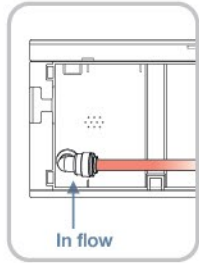

1 Should water with a temperature higher than 95 °F (35°C) get into the unit, the water supply will automatically be shut off and the unit will stop operating.



2 LCD: "TEMP ERROR"

3 Bring the source water temperature into the proper range.

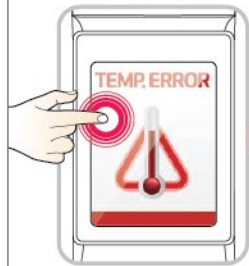

4 If you press the error icon, the display will switch to standby mode (home screen)



5 When your source water is within the proper range, the ionizer will resume the proper function and the water will flow.

※ For the best functionality, there may be some changes without prior notice.

## UNIT SPECIFICATIONS

Model Number	UCE-E13T PLUS	UCE-E11T PLUS	UCE-E9T PLUS
Electrolytic Cell Quantity of Poles	13	11	9
Power Consumption	Max 220W		
TURBO Function	O		
Product Name	TYENT Water Ionizer		
Purifying Mode	DM filtration mode		
Rated Voltage	100 -130 V~ <input checked="" type="checkbox"/> , 200 -240 V~ <input type="checkbox"/> / 50-60 Hz <input type="checkbox"/>		
Available temperature	4 -35°C (39 -95°F)		
Operating Pressure Range	0.1- 0.5 MPa		
pH Levels	3 Alkaline, 1 Neutral, 3 Acidic, Turbo		
Adjustable pH	User-adjustable pH levels control		
Filters Configuration	2-Filters system		
Filter Life Display	LCD filter replacement and announcement		
Water Cell Plate Materials	Platinum and Titanium		
Product Size	Dispenser : D2 * H13.5(inch) / D50 * H343(mm) Ionizer : W11.8*D5.3*H13.9(inch) / W300*D136.5*H355(mm)		
Product Weight	Ionizer - 12.1 Lbs / Dispenser - 3.9Lbs Ionizer - 5.5kg / Dispenser - 1.8kg		

※To make the best functionality, there may be some change without notices.



Before requesting service, please make sure to check the following :

## TROUBLESHOOTING

### Q. Abnormal taste

1. Check the period of use.
  - **Run the unit for one minute, draining stagnant water.**
2. Check the filter for replacement time.
  - **Replace the filter.**

### Q. Water outflow change

1. Check if the valve on the water supply is closed.
  - **Open Valve.**
2. Check if the hose is bent or folded.
  - **Stretch out the hose.**
3. Check if the flow rates are low (less than 1ℓ/ min.).
  - **You'll need to install a water pump. Please consult with a Tyent technician.**
4. Check if your water supply is cut off or if the water supply line is frozen.
  - **Wait until the water comes out of the water supply pipe.**
5. Check your filters for a clog.
  - **Change the filters.**

### Q. Incorrect pH levels

1. Check the hardness of your source water (inflow water).
  - **Water quality varies by region.**
2. Check flow rates for higher levels.
  - **Reduce the amount of raw water.**
3. Check whether the amount of drained water is small.
  - **Please contact a Tyent technician.**  
Request after-sales service.

### Q. Filter usage icon remains 100% even after the filter has been replaced

- Check whether the filter usage has been reset.
- **Reset the filter usage.**

### Q. The unit stops during use

- Check whether the operating time exceeds 15 min. \*Turbo: 5 min
- **The unit stops automatically after 15 min.**

### Q. The unit leaks

1. Check the filter for proper mounting.
2. Check the faucet and water ionizer body are properly connected.
  - **Unplug the unit and then contact a Tyent technician.**

### Q. Sediment in extracted water

- Check for excessive calcium in your source water (inflow water).
- **Contact Tyent for replacements filters.**

### Q. Only purified water is extracted

- Check whether the flow rate is high (5 kgf/cm<sup>2</sup> or faster).
- **Contact a Tyent technician to install a pressure reducing valve.**

### Q. The Unit does not operate in cleaning mode

1. Check whether the outflow has reached the set "Cleaning Cycle" value or time.
2. Check whether the operating time exceeds 24 hours.
3. Check whether the Cleaning button is pressed.
  - **The unit returns to normal after performing an auto-cleaning cycle for 15 seconds.**

### Q. The screen turns off

- Check whether the non-operating time exceeds 10 minutes.
- **When you're not using the unit for 10 minutes, it changes to ECO mode automatically. The unit returns to normal mode after touching the screen.**

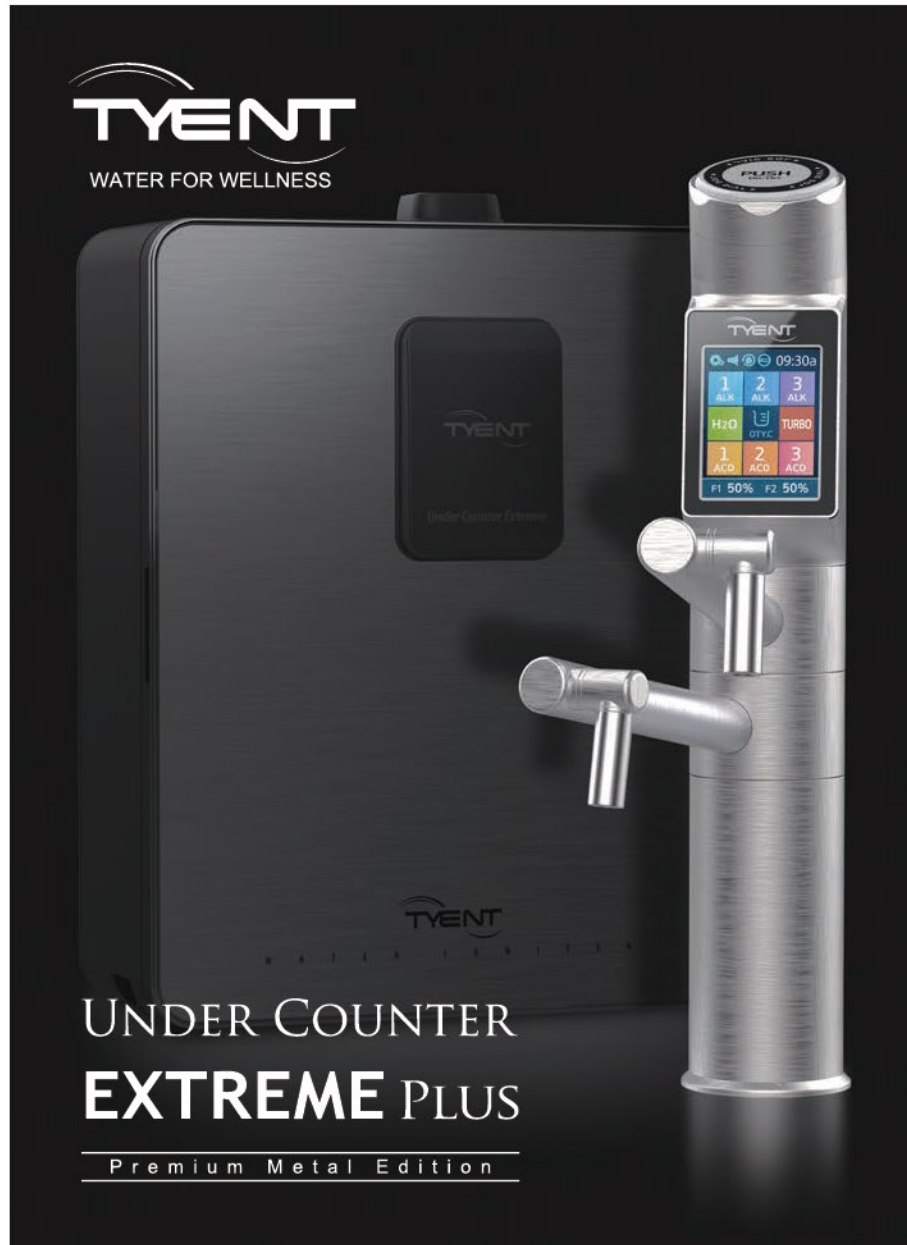

## Product Warranty

1. This product features a lifetime warranty. If any manufacturing defects or spontaneous failures occur during the warranty period, the unit will be repaired or replaced at no charge.
2. If any failure occurs, please call the service center. Note: The answers to many service questions can be found online at [tyentusa.com/support](http://tyentusa.com/support).
3. In case of a failure resulting from the customer's negligence or intentional damage of the product, the customer shall be responsible for repair or replacement costs.
4. This warranty is non-transferable and valid only for the original owner.

Product Name	Water Ionizer	Warranty Period
Tyent Water Ionizer	<input type="checkbox"/> UCE-E13T PLUS <input type="checkbox"/> UCE-E11T PLUS <input type="checkbox"/> UCE-E9T PLUS	Lifetime (above conditions apply)

Customer's Name/Phone	Date of Purchase
Customer's Address	Installation Date/Name



Tyent USA, LLC  
[www.tyentusa.com](http://www.tyentusa.com)



137 Hurffville Crosskeys Rd, Sewell, NJ 08080  
 Toll Free: 855-TYENT-US